



WILBUR CURTIS Co., Inc.

Service Manual – RU Series Automatic Urns

Important Safeguards/Symbols

This appliance is designed for commercial use. Any servicing other than cleaning and maintenance should be performed by an authorized Wilbur Curtis service center.

- To reduce the risk of fire or electric shock, do not open side or bottom panel. There are no user serviceable parts inside.
- All repairs should only be performed by authorized service personnel.
- Keep hands and other items away from hot parts of the unit during operation.
- Never clean with scouring powders, bleach or harsh chemicals.

Symbols:



WARNING/CAUTION – To advise about conditions that may result in property damage, personal injury or death



IMPORTANT – Notes about proper operation



NSF Sanitation requirements

The RU Automatic Urn is factory pre-set and ready to go... right from the carton.

Factory Settings:

- Brew Temperature = 200°F
- Brew Volume = Set to requirements of coffee liner

System Requirements

- Water Source: 20 – 100 psi (minimum flow rate of 1 gpm)
- Electrical: See attached schematic for standard model or visit www.wilburcurtis.com for your model.



CAUTION: Please use the setup procedures in this manual before attempting to use the brewer. Failure to follow the instructions can result in injury or the voiding of the warranty. See setup procedures on page 2.

Brewing Instructions

1. Place filter in basket. Pour coffee into filter. Place basket into liner.

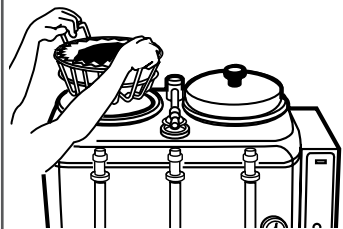

2. Rotate spray head over bed of coffee inside filter.

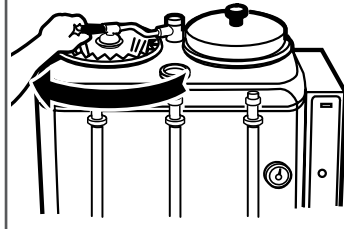

3. Press BREW button on control panel to begin brewing.

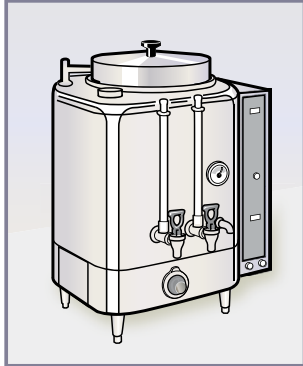
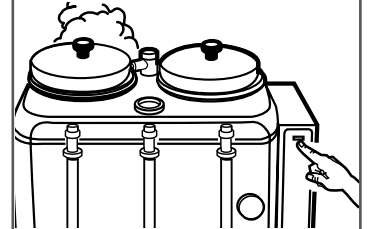

MODELS INCLUDED

- RU-150
- RU-225
- RU-300
- RU-600
- RU-1000



WARNING: HOT LIQUID, Scalding may occur. Avoid splashing.

ISO 9001:2008 REGISTERED

WILBUR CURTIS CO., INC.
6913 West Acco Street
Montebello, CA 90640-5403
For the latest information go to
www.wilburcurtis.com
Tel: 800-421-6150
Fax: 323-837-2410

Technical Support: 800-995-0417 M-F 5:30 A.M. - 4:00 P.M. PT
Email: techsupport@wilburcurtis.com

INSTALLATION AND OPERATING INSTRUCTIONS

SETUP STEPS



WARNING: DO NOT place this urn closer than six [6] inches from wall. Urn must have adequate cross-ventilation.



NOTE: A water filtration system must be used to help maintain trouble-free operation. **Air must be purged from the cartridge prior to connection to equipment.** In areas with extremely hard water, we recommend the use of a Curtis approved water filter. For our full line of filters, please log on to www.wilburcurtis.com.

1. Attach adjustable legs, threading them into the holes beneath the four corners of the urn.
2. Place unit at counter height, on a firm, level base, near water and power supply connections. Level it left to right and front to back by rotating the feet on the 4 corners.



WARNING: Use the leveling legs to level the brewer only. Do not use them to adjust brewer height. Do not extend them higher than necessary.

3. Install the water and coffee faucets.
4. Connect water line to inlet fitting on valve. All Curtis automatic urns are equipped with a 1/4" male flare fitting which must be connected to the water supply with a 1/4" copper tubing and a 1/4" flare nut. Water pressure entering brewer is required to be stable and must provide minimum of 1 gallon per minute. Use water regulator for constant pressure. Required water pressures, 20 to 100 psi.



CAUTION: DO NOT connect this urn to hot water. The inlet valve is not rated for hot water.

5. Turn on water valve.
6. Hook-up electrical power to the unit (refer to schematic for power requirements). If gas or steam, 120V circuit is required.
7. When power is turned on, water will start flowing into the water jacket. To expedite the filling of the urn, you may use the emergency refill valve located behind the machine.



CAUTION: Don't forget to close the valve once the water jacket has filled.

8. When the water jacket has filled, turn on the thermostat by turning the dial clockwise to the desired setting. It will take 50 to 60 minutes for the heating tank to reach operating temperature. On electric urns, the thermostat indicator will light at this time.



WARNING: When you hookup an electric urn, use the proper wire gauge, plus 25% (see table on page 12). Never use fuses or breakers larger than needed.

The body of the urn must be securely grounded with a separate grounding conductor and never with the neutral conductor of a single phase, 3 wire system. Refer to the wiring diagram included with each urn for wire gauge.

CARE AND MAINTENANCE OF URN

PREVENTIVE MAINTENANCE

1. Remove the spray head from the urn and clean it once a week. More often in heavy lime areas.



WARNING: Switch off the power to the unit at the circuit breaker. Turn off the water line running to the urn.

2. Clean the faucet seat cups twice a week and replace when cracked or leaking.
3. Periodic temperature checks and thermostat adjustments should be made by authorized personnel.

CLEANING

To ensure the highest quality coffee, the urn must be cleaned daily after the last batch of coffee is used.

Regular cleaning and preventive maintenance is essential in keeping your coffee urn looking and working like new.



CAUTION: Do not use cleaning products containing chemicals that will damage stainless steel, ammonia and bleaches containing chlorine. Never use abrasives that will scratch the outside surface of the urn.

DAILY CLEANING INSTRUCTIONS



WARNING: These steps involve working with very hot water.

1. After all the brewed coffee has been drawn from the urn, run a brew cycle of fresh water. Spray the hot water into the liner, then thoroughly brush it out with a long handled brush.
2. Drain the water off then repeat step one. Run another brew cycle. Brush out the liner and drain. Wipe down the liner with a clean towel.
3. If urn is not going to be used immediately, pour a gallon or two of fresh water into the liner. Remember to drain off this water before making another brew.
4. Wash the wire brew baskets with urn cleaner and rinse thoroughly.

TWICE A WEEK

The coffee urn liner must be scoured twice a week:

1. Be sure water jacket is full of water and at brewing temperature.
2. Fill the liner with several gallons of water and add at least 1½ ounces of coffee urn cleaning compound. Allow this solution to remain in the liner approximately 30 minutes. During this time, the thermostat should be set to BOIL.



WARNING: Very hot water.

3. Scrub the inside of the liner and cover with a long handled brush.
4. Drain all the urn cleaning solution and rinse by running several brew cycles with the spray head centered over the liner, draining the rinse water between sprays.
5. Thoroughly clean the faucets.



WARNING: Never remove the faucet when the liner has water or coffee in it.

Switch off the power to the unit at the circuit breaker. Turn off the water line running to the urn.

Use a long thin gauge glass brush to clean the coffee gauge glass. Use the same brush to clean the fitting at the bottom of the liner and the pipe connecting to the coffee faucet.

6. Leave a gallon or two of fresh water in the liner. Drain just before brewing coffee.
7. After the unit is clean, turn on the water supply and power to the unit.

ILLUSTRATED PARTS LIST AUTOMATIC URNS, RU-150, RU-225, RU-300, RU-600, RU-1000 ELECTRIC

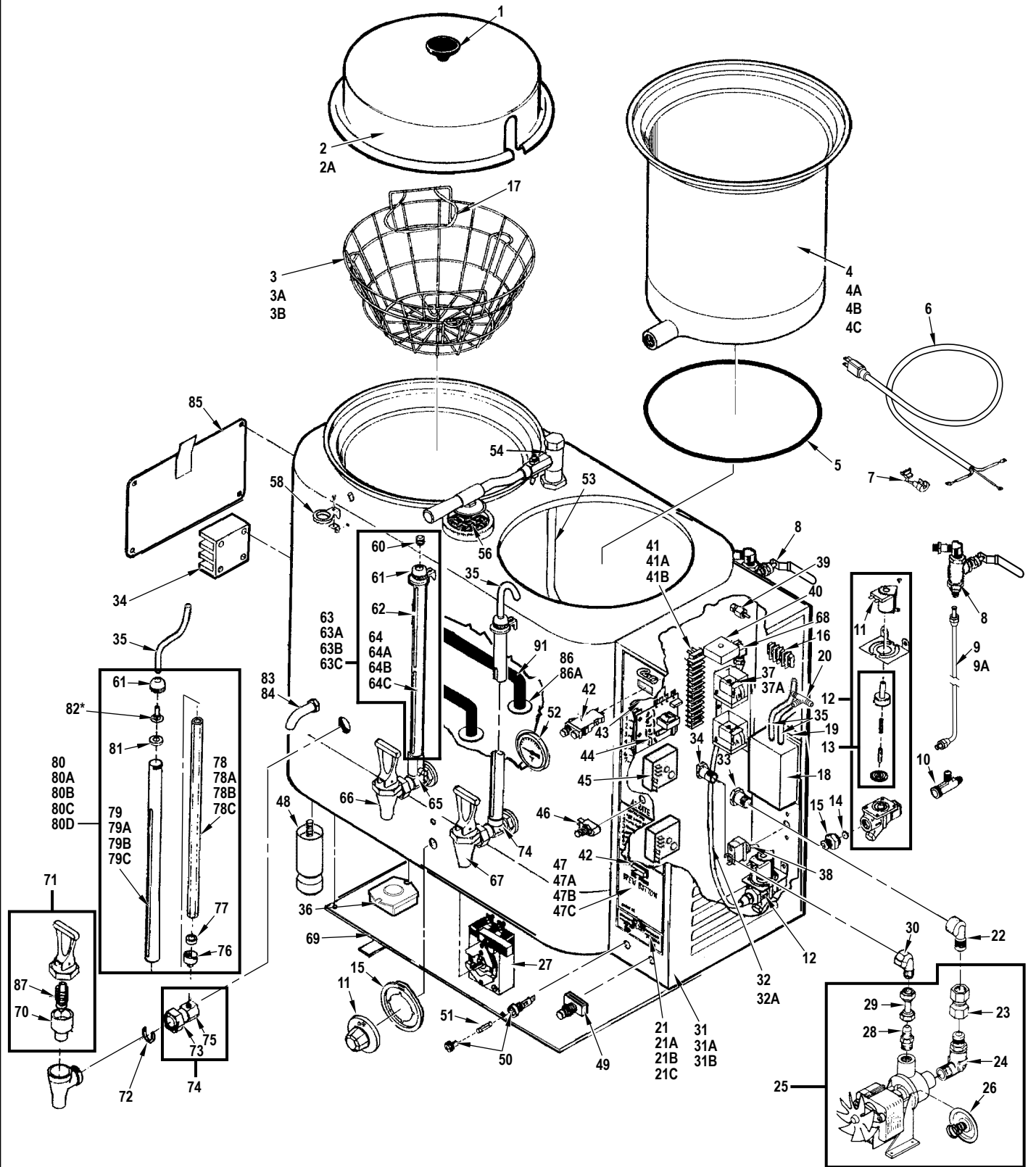

*82 NOT INCLUDED WITH GAUGE GLASS ASSEMBLY.

INDEX №	PART №	DESCRIPTION	EQUIPMENT USED ON
1	WC-3205	KNOB, LID 1/4-20 FEMALE THRD USE ON WC-5601/2/3	ALL RU URNS
2	WC-5601	LID, LINER ASSY (SC)RU-150/300	RU-150, RU-300
2A	WC-5603	LID, LINER ASSY RU225/600/1000	RU-225, RU-600, RU-1000
3	WC-3302	BREW BASKET WIRE W/FLAPS RU-300	RU-150, RU-300
3A	WC-3303	BREW BASKET, WIRE W/ FLAPS RU-600	RU-225, RU-600
3B	WC-3304	BREW BASKET, WIRE W/ FLAPS RU-1000	RU-1000
4	WC-5700	LINER, 3 GAL RU-150	RU-150
4A	WC-5706	LINER, 6 GAL RU-600	RU-225, RU-600
4B	WC-5704	LINER, 3 GAL RU-300	RU-300
4C	WC-5708	LINER, 10 GAL RU-1000	RU-1000
5	WC-4303	O-RING, LINER RU-150/300	RU-150, RU-300
5A	WC-43076	O-RING, LINER, RU'S, 6, 10 GA	RU-225, RU-600, RU-1000
6	WC-1200	CORD, 14/3 SJTO 6' BLK W/PLUG	ALL GAS, STEAM & 3Ø RU URNS
7	WC-1408	GRIP, CORD 7/8" OD	ALL GAS, STEAM & 3Ø RU URNS
8	WC-806	VLVE, 1/4" BR. BALL ASSY EMERGENCY REFILL RU'S	ALL RU URNS
9	WC-53104	TUBE ASSY, 1/4x14.50 ER W/NUTS RU-150/300	RU-150, RU-300
9A	WC-53105	TUBE ASSY, 1/4x17.00 ER W/NUTS RU-225/600	RU-225, RU-600
9B	WC-53109	TUBE ASSY, 1/4" ER W/NUTS RU-1000	RU-1000
10	WC-2705	TEE, 1/4 X 1/4 FLARE X 3/8 NPT PLATED	ALL RU URNS
11	WC-3217	KNOB, ELECTRIC THERMOSTAT RU	ALL RU URNS
12	WC-801	VALVE, INLET BRASS .50 GPM 120V 10W RU/WB	ALL RU URNS
13	WC-3700	KIT, INLET VAL. REP. USE ON WC-801/801R/885/890/858	ALL RU URNS
14	WC-813	FLOW WASHER, .5GPM .5" S45	ALL RU URNS
15	WC-3220	BEZEL, THERMOSTAT ELECTRIC URN'S	ALL RU URNS
16	WC-301 ¹	TERMINAL STRIP, 4-S	ALL RU URNS (BEFORE 1/29/13)
17	WC-3305	FLAP, WIRE BASKET RU150/300 (2 REQUIRED)	RU-150 & RU-300
18	WC-37166	KIT, AIR PUMP RU'S	ALL RU URNS
19	WC-5843	BRACKET, AERATOR PUMP RU	ALL RU URNS
20	WC-3600	TEE, CONNECTOR 3/16 POLYPROPYLENE	RU-150 & RU-225
21	WC-38570	LABEL, INSTRUCTION PANEL RU150/RU-300	RU-150 & RU-300 (AFTER 1/29/13)
21A	WC-38571	LABEL, INSTRUCTION PANEL RU225/RU-600	RU-225 & RU-600 (AFTER 1/29/13)
21B	WC-38574	LABEL, INSTRUCTN PANEL RU1000	RU-1000 (AFTER 1/29/13)
22	WC-2405	ELBOW, 1/2 FLARE x 1/2 NPT	ALL RU URNS
23	WC-2609	SWIVEL, 1/2" TUBE X 1/2 NPT	ALL RU URNS
24	WC-2504	ELBOW, 1/2 NPT X 1/2 NPT	ALL RU URNS
25	WC-1037	PUMP, WATER W/FITTINGS 120VAC	ALL RU URNS
26	WC-3702	KIT, WATER PUMP SEAL RU'S USE ON WC-1000	ALL RU URNS
27	WC-37165	KIT, THERMOSTAT WC-500A/501A	ALL RU URNS
28	WC-2605	CONNECTOR, 3/8 FLARE X 3/8 NPT	ALL RU URNS
29	WC-2608	SWIVEL, 3/8 TUBE x 3/8 NPT	ALL RU URNS
30	WC-2403	ELBOW, 3/8 FLARE x 3/8 NPT PLATED GEN USE	ALL RU URNS
31	WC-5808	DOOR, CONTROL BOX LOUVER, RU-225/600	RU-225, RU-600
31A	WC-5807	DOOR, LOUVER ACB RU150/300	RU-150, RU-300
31B	WC-5809	DOOR, CONTROL BOX LOUVER RU-1000	RU-1000
32	WC-5322	TUBE ASSY, 1/4x20.00 WI W/NUTS	RU-225, RU-600
32A	WC-5321	TUBE ASSY, 1/4x17.00 WI W/NUTS	RU-150, RU-300
33	WC-2929P	FITTING, 1/2 NIPPLE/NUT PLATED	ALL RU URNS
34	WC-300	POWER BLOCK 3-STA 175A 600V RU'S	ALL RU URNS
35	WC-5307	TUBE, 3/16 ID x 3/32W SILICONE GEN USE	ALL RU URNS
36	WC-522	THERMO., HI LIMIT HEATER CONTROL DPST 277V 40A	ALL RU URNS
37	WC-402 ^{1,2}	RELAY, HOLDING 120V COIL 10A RU'S	ALL RU URNS (BEFORE 1/29/13)
37A	WC-403 ^{1,2}	RELAY HOLDING 120V 3 POLE 6.6A RES.@240V	RU-1000 (BEFORE 1/29/13)
38	WC-102	SW, TOG NON-LIT SPST 15A 125/6A 250VAC RESIST.	ALL RU URNS

¹ OLDER UNITS

² ITEMS 37 AND 37A, AFTER 1/29/13 SEE ITEMS 45, 45A, 45B

INDEX №	PART №	DESCRIPTION	EQUIPMENT USED ON
39	WC-5502-01	KIT, PRB, ASSY WATER LVL W/HEX FITTING, O-RNG & NUT	ALL RU URNS
40	WC-405R-101	TIMER, AGITATION 90-260 VAC 30 SEC	ALL RU URNS
40A	WC-405R	TIMER, AG. 120V 50/60HZ W/WIRES & BRKT RU'S	ALL RU URNS
41	WC-304 ¹	TERMINAL STRIP, 14-S(RU1,6)	RU-225, RU-600, RU-1000
41A	WC-303 ¹	TERMINAL STRIP 12-S	RU-150, RU-300
41B	WC-302 ¹	TERMINAL STRIP, 6-S(GM,CRA)	RU-1000
42	WC-3737	KIT, BREW SWITCH 120V RU'S	ALL RU URNS
43	WC-5802 ¹	BRACK., WTR LVL. CONT. RU-150/225/300/600/1000	ALL RU URNS
44	WC-608-101K	KIT, LIQUID LEVEL CONTROL BOARD RETROFIT	ALL RU URNS
45	WC-603-101K-RU	KIT, RET. TIMER, BREW SELECTOR 120V RU-300 W/1/2BB NOTE: 120V RU URNS BUILT BEFORE JAN. 2013	SEE NOTE
45A	WC-603-101	TIMER, BREW SELECTOR 120V 2-20 MIN GEM-120A/RU'S NOTE: 120V RU URNS (EXCEPT RU-1000) BUILT JAN. 2013 AND AFTER	SEE NOTE
45B	WC-603-102	TIMR., BRW. SELT. 120V 2-20 MIN W/FULL & 1/3 BTCH OPT NOTE: 120V RU-1000 URNS BUILT BEFORE JAN. 2013	SEE NOTE
45C	WC-622-101K-RU	KIT, RETROFIT BREW TIMER FULL & 1/3 BATCH 220V RU NOTE: 208/220V RU URNS BUILT BEFORE JAN. 2013	SEE NOTE
45A	WC-622-101	TIMER, BREW SELECTOR 220V 2-20 MIN GEM-120A/RU'S NOTE: 208/220V RU URNS (EXCEPT RU-1000) BUILT JAN. 2013 AND AFTER	SEE NOTE
45B	WC-622-102	TIMER, BRW SEL. 220V 2-20 MIN W/FULL & 1/3 BTCH OPT NOTE: 208/220V RU-1000 URNS BUILT BEFORE JAN. 2013	SEE NOTE
46	WC-101	SWITCH, ON/OFF NON-LIT SPST MOMENT. 3/6A 250/120V	ALL RU URNS
47	WC-3903	LABEL, INSTRUCT'S PANEL CURTIS RU-600	RU-600
47A	WC-3900	LABEL, INSTRUCTION PANEL RU150	RU-150
47B	WC-3901	LABEL, INSTRUCTION PANEL RU225	RU-225
47C	WC-3902	LABEL, INSTRUCT'S PANEL CURTIS RU-300	RU-300
47D	WC-3904	LABEL, INSTRUCT'S PANEL CURTIS RU1000	RU-1000
48	WC-3528	LEG, 4" ADJUSTABLE 3/8-16 THRD ITALIAN STYLE	ALL RU URNS
49	WC-100	SW, RES-STOP N.C.NON-LIT SP MOMENT 10/15A 250/120V	ALL RU URNS
50	WC-1501	FUSE, HOLDER ASSY W/5A FUSE	ALL RU URNS
51	WC-1500	FUSE, 5 AMP	ALL RU URNS
52	WC-511	THERMOMETER, DIAL RU'S	ALL RU URNS
53	WC-5313	TUBE, SPRAYARM ASSY W/NUTS RU-300	RU-300, RU-150
53A	WC-5314	TUBE, SPRAYARM ASSY W/NUTS RU-600	RU-225, RU-600
53B	WC-5315	TUBE, SPRAYARM ASSY W/NUTS RU-1000	RU-1000
54	REFER TO VALVE	CORE & SPRAY ARM ON PAGE 8	
56	WC-5800	RING, STEAM	ALL RU URNS
58	WC-2007	BRACKET, GAUGE GLASS GEM-3	ALL RU URNS
60	WC-2003	CAP, PLUG VENTED 44	ALL RU URNS
61	WC-2002	CAP, SHIELD W/CLEAN OUT	ALL RU URNS
62	WC-2030	GLASS, GAUGE 13"	RU-225, RU-600
63	WC-2108	GAUGE GLASS ASSEMBLY 13" USE ON RU-225	RU-225, RU-600
63A	WC-2104	GAUGE GLASS ASSEMBLY 10"	RU-150
63B	WC-2105	GAUGE GLASS, ASSY 11" USE ON RU-150/300	RU-150, RU-300
63C	WC-2113	GAUGE GLASS, ASSY 19"	RU-1000
64	WC-2017	SHIELD, GAUGE GLASS 13"	RU-225, RU-600
64A	WC-2104	SHIELD, GAUGE GLASS 10"	RU-150
64B	WC-2014	SHIELD, 11" GAUGE GLASS	RU-300
64C	WC-2022	SHIELD, 19" GAUGE GLASS 1/8 NPT	RU-1000
65	WC-1900	VALVE, GAUGE SHIELD SHUT-OFF 1/8 NPT	ALL RU URNS
66	WC-1800L	FAUCET, "S" SERIES LOCKING 1-1/32-14 UNS	ALL RU URNS
70	WC-1805	SEAT CUP, "S" FAU USE ON WC-1800/B/LB/D/DL/L/WC-1803	ALL RU URNS
71	WC-3705	KIT, FAUCET S SERIES NONLOCK USE ON WC-1800	ALL RU URNS
72	WC-1906	C' RING .917 X .760 X .090 TT-3 TC'S	ALL RU URNS

¹ OLDER UNITS

INDEX №	PART №	DESCRIPTION	EQUIPMENT USED ON
73	WC-1903	NUT, UNION SHANK WB-10/WB-10-60/WB-30-12	ALL RU URNS
76	WC-2004	BASE, SHIELD GAUGE GLASS GEN USE	ALL RU URNS
77	WC-2006	WASHER, .188 ID X .188 THK BOTTOM GAUGE GLASS GEN USE	ALL RU URNS
78	WC-2031	GLASS, GAUGE 14"	RU-225, RU-600
78A	WC-2028	GLASS, GAUGE 5/8" X 11"	RU-150, RU-300
78B	WC-2029	GLASS, GAUGE 5/8" X 12"	RU-300
78C	WC-2037	GLASS, GAUGE 5/8" X 20"	RU-1000
79	WC-2019	SHIELD, 14c" GAUGE GLASS	RU-600
79A	WC-2014	SHIELD, 11" GAUGE GLASS	RU-150, RU-300
79B	WC-2016	SHIELD, GAUGE GLASS 3/4D.X 12"	RU-300
79C	WC-2023	SHIELD, 20" GAUGE GLASS	RU-1000
80	WC-2109	GAUGE GLASS, ASSY 14"	RU-600, RU-225
80A	WC-2105	GAUGE GLASS, ASSY 11" USE ON RU-150	RU-150
80B	WC-2107	GAUGE GLASS, ASSY 12" SHORT WIN	RU-300
80C	WC-2114	GAUGE GLASS, ASSY 20"	RU-1000
81	WC-2005	SHIELD CAP, WASHER, 1/8" GEM-3/TC'S W/SG	ALL RU URNS
82	WC-2000	FITTING, AGITATION PLATED RU'S	ALL RU URNS
83	WC-4205	NUT, 1/4 LOCK NPS BRASS	ALL RU URNS
84	WC-2913	SPOUT OVERFLOW	ALL RU URNS
85	WC-5810	COVER, W/A ELECTRIC BOX RU'S RU-600,1000	RU-600, RU-1000
86	WC-43123	O'RING, .549 ID X .103CS SILI CONE FOR HEATING ELEMENT	ALL RU URNS
86A	WC-4305 ¹	WASHER 5/8" TEFLON	ALL RU URNS
87	WC-3402	SPRING, RETURN "S"SERIES FAUCT	ALL RU URNS
88	—	REFER TO HEATING ELEMENT CHART ON PAGE 9	
89	WC-431	CONTACTOR, 120V 60A 3P DP (NOT SHOWN)	ALL RU URNS

PARTS LIST DOUBLE SERVICE URNS (NOT SHOWN)

90	WC-5701	LINER, 3 GAL D/S RU-150	RU-150DS
91	WC-5703	LINER, 6 GAL D/S RU-225	RU-225DS
92	WC-5705	LINER, 3 GAL D/S RU-300	RU-300DS
93	WC-5707	LINER, 6 GAL D/S RU-600	RU-600DS
94	WC-5709	LINER, 10 GAL D/S RU-1000	RU-1000DS
95	WC-5458	PLATE, RING STEAM D/SERVICE	ALL DS RUs

PARTS LIST 220V, 3 PHASE URNS (3W +G or 4W +G - NOT SHOWN)³

96	WC-703	TRANSFORMER, .5KVA 240-120V RU'S	ALL 220V 3-PH RU
97	WC-710	TRANSFORMER, 240/480 120V,500VA RU/PCGT/CAFEPCC	ALL 220V 3-PH RU
98	WC-1200	CORD, 14/3 SJTO 6' BLK W/PLUG	ALL 220V 3-PH RU
99	WC-1408	CORD GRIP, 7/8" O.D.	ALL 220V 3-PH RU
100	WC-37165	KIT, THERMOSTAT WC-500A/501A	ALL 220V 3-PH RU
101	WC-502 ¹	THERMOSTAT, CAPILLARY LWC OFF DPST	ALL 220V 3-PH RU

PARTS LIST EXPORT 220V CONTROLS (NOT SHOWN)³

102	WC-3738	KIT, BREW SWITCH 220V RU RPLL	ALL 220V RU
103	WC-417 ¹	RELAY, HOLDING 220V 2P 10A RU	ALL 220V RU
104	WC-622-101K-RU	KIT, RETROFIT BREW TIMER FULL & 1/3 BATCH 220V RU	RU-300 NO 1/2BB
105	WC-633 ¹	TIMER, CUBE W/BACKET 240V 25 SECS	ALL 220V RU
106	WC-858	VALVE, INLET BRASS .50 GPM 220V 10W	ALL 220V RU
107	WC-1009	PUMP, AGITATION 220V	ALL 220V RU

¹ OLDER UNITS

³ REFERENCE THE ELECTRICAL DIAGRAM FOR YOUR SPECIFIC UNIT.

SPRAY ARM ASSEMBLY

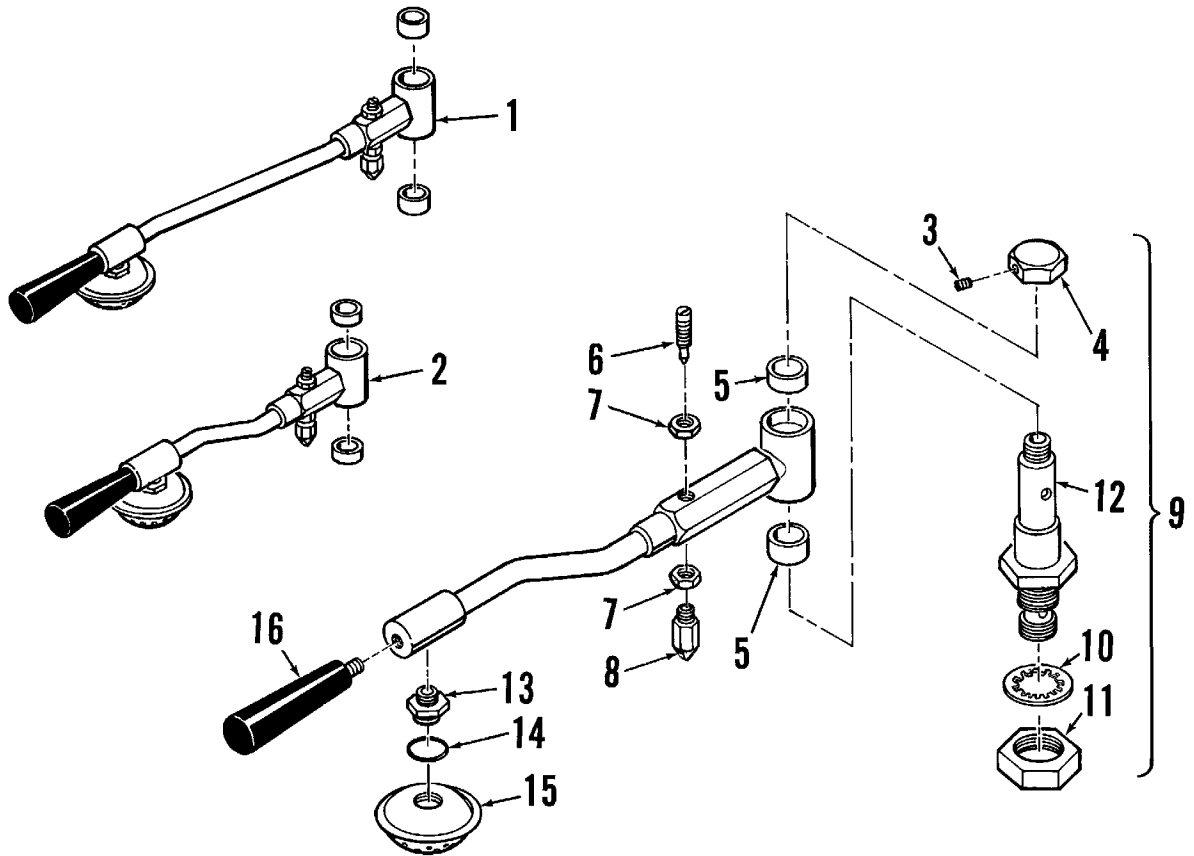

INDEX №	PART №	DESCRIPTION
1	WC-2909	SPRAY ARM ASSEMBLY, RU-225/600/1000
2	WC-2908	SPRAY ARM ASSEMBLY, RU-300, RU-150
3	WC-4800	SCREW, 8-32 x 1/8" SET S.S.
4	WC-3103	CAP, CLEAN OUT VALVE CORE PLTD RU's
5	WC-4307	RING, PACKING TEFLON 2-REQ
6	WC-2916	NEEDLE, BY PASS PLTD (SPRAY ARM)
7	WC-4202	NUT, 3/8" - 24 JAM, PLATED
8	WC-2914	SPOUT, BY PASS PLTD (SPRAY ARM)
9	WC-3753	KIT, VALVE CORE REPLACEMENT
10	WC-4310	WASHER, 7/8" INTERNAL TOOTH LOCK 410 STAINLESS STEEL
11	WC-4215P	NUT, 7/8" JAM PLATED
12	WC-3109	VALVE CORE, PLATED
13	WC-2904	SPRAY HEAD HOLDER PLATED
14	WC-4320	O'RING, 1/2" I.D.
15	WC-2907	SPRAY HEAD, ASSY (SC)RU-150/225/300/600/1000
16*	WC-3200	HANDLE, SPRAY ARM BLACK PLASTIC RU/MWM

* Use only with valve cores that do not have Teflon retractors.

HEATING ELEMENTS, LOCATION & CONFIGURATION

RU-150 & WB-14 1 PHASE

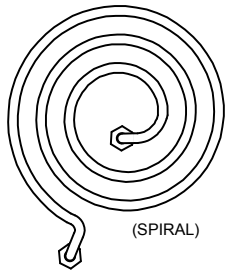

WC-913-01
220V, 5 KW

(SPIRAL)

RU-225 1Ø

220V, 1PH, 3 WIRE + GND

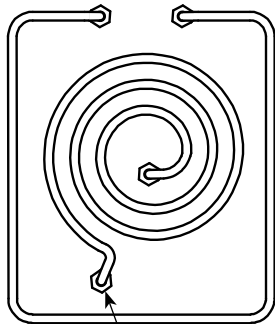

WC-911 -01
220V, 3.5KW

WC-911-02
220V, 3.5 KW

-01 (EXTERIOR) -02 (CENTER)

RU-150 & 225 3 PHASE

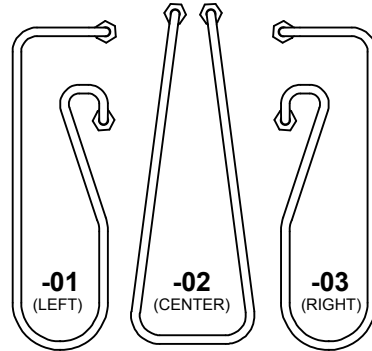

RU-150-20 5.25 KW, 208/220V, 3PH, 3 OR 4 WIRE + GND.

WC-907-01 220V @ 1.75 KW

WC-907-02 220V @ 1.75 KW

WC-907 -03 220V @ 1.75 KW

RU-225-20 7.5 KW, 208/220V, 3PH, 3 OR 4 WIRE + GND.

WC-908-01 220V @ 2.5 KW

WC-908-02 220V @ 2.5 KW

WC-908-03 220V @ 2.5 KW

RU-300, 600 & 1000 3 PHASE

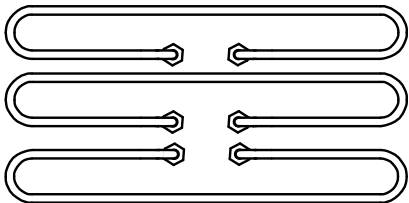

THESE ELEMENTS ARE INTERCHANGEABLE

RU-300 7.5 KW, 208/220V, 3PH, 3 OR 4 WIRE + GND.
3 - WC-908 220V @ 2.5 KW EA.

RU-600 10.5 KW, 208/220V, 3PH, 3 OR 4 WIRE + GND.
3 - WC-911 220V @ 3.5 KW EA.

RU-1000 10.5 KW, 208/220V, 3PH, 3 OR 4 WIRE + GND.
3 - WC-911 220V @ 3.5 KW EA.

RU-300, 600 & 1000 1 PHASE

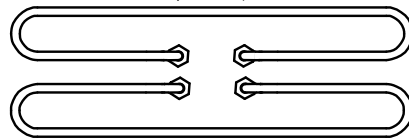

THESE ELEMENTS ARE INTERCHANGEABLE

RU-300 6 KW, 208/220V, 1PH, 3 WIRE + GND
2 - WC-910 220V @ 3 KW EACH

RU-300 8 KW, 208/220V, 1PH, 3 WIRE + GND
2 - WC-912 220V @ 4 KW EA.

RU-600 10 KW, 220V, 1PH, 3 WIRE + GND
2 - WC-913 220V @ 5 KW EACH

RU-600 8 KW, 220V, 1PH, 3 WIRE + GND
2 - WC-912 220V @ 4 KW EACH

RU-1000 10 KW, 220V, 1PH, 3 WIRE + GND
2 - WC-913 220V @ 5 KW EACH

ELECTRIC THERMOSTAT ADJUST

On electric urns, thermostats are set at the factory to cut off at 200°F. We do not recommend changing this setting. If necessary, adjustment is as follows:

1. Rotate the thermostat knob to the right, to the BOIL position. Pull off the knob.
2. In the thermostat stem, locate the tiny adjustment screw (see illustration). Using a small screwdriver, adjust the temperature up or down:
 - a. Turning the screw $\frac{1}{4}$ turn to the left will increase the temperature about 20°F.
 - b. Turning the screw $\frac{1}{4}$ turn to the right will decrease the temperature by 20°F.
 - c. To set the thermostat precisely at 200°F, insert a thermometer probe into the water

jacket through the steam hole (just under the spray head). Turn the screw $\frac{1}{2}$ turn to the left. When the thermometer reaches 200°F, slowly turn the adjustment screw to the right until the pilot light turns off.

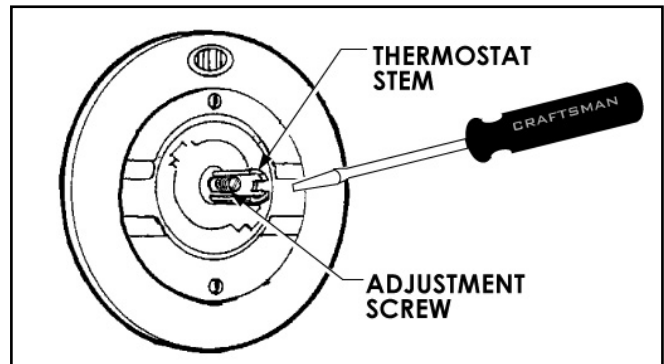

GAS URN INSTALLATION

The urn must be away from the wall no less than 6" and must have plenty of cross ventilation.

The water supply connection is the same in all RU models. All that is needed is $\frac{1}{4}$ " copper tubing with a $\frac{1}{4}$ " flare nut and some sort of water filter in the line, before water enters the unit. Once the water connection is complete, open the water line, then plug in the power cord into an 115 V outlet. To facilitate the filling of the water jacket, you can open the emergency refill faucet (red knob) behind the unit, to increase the speed of filling the urn. Water must be above the base of the center gauge glass before turning on the heat.



IMPORTANT: Be sure to shut off the emergency refill valve after filling, to prevent overflow!

GAS CONNECTION

All RU automatic urns are supplied with a $\frac{3}{8}$ " pressure connector at the end of the gas valve. This valve is connected to the thermostat. Use $\frac{3}{8}$ " O.D. stainless steel flex tubing to make the connection from the urn to the gas valve in your facility. When the connections are complete, turn the gas on. Check the line for leaks.

MAIN BURNER ADJUSTMENT

To adjust the main burner flame, turn the thermostat dial to $6\frac{1}{2}$ for 195°F or 7 for 200°F. For older units (made before serial number 12327781), turn the screw under the gas cock handle in either direction to regulate the flow of gas to the main burner.

PROCEDURE FOR LIGHTING OR RELIGHTING

1. Turn the GAS COCK handle to the OFF position, and the thermostat dial to the lowest temperature position.
2. Wait a sufficient amount of time to allow gas that may have accumulated in the burner compartment to escape.
3. Turn the pilot dial to the PILOT position.
4. Push in the pilot dial (it has a slight inward travel) and rotate it to the PILOT position. On older units, there is a separate red SET button that must be pushed in to allow the dial to turn.
5. Continue pressing in on the dial while lighting the pilot burner. The pilot is located inside the burner compartment, between the main burners.
5. Once lit, continue pressing in on the dial for 30 seconds. If the pilot flame does not remain lit, repeat operation allowing longer period before releasing the pilot dial.
6. Turn the pilot dial to the ON position. Turn the thermostat dial to the desired position. The main burner will then ignite.

PROCEDURE FOR ADJUSTING PILOT

1. Remove the pilot adjustment cap. Adjust the pilot key, allowing the flame to completely envelop the end $\frac{3}{8}$ " of the thermocouple.
2. Adjust the pilot burner air shutter (if provided) to obtain a soft blue flame.

TO RE-CALIBRATE THE THERMOSTAT

The Unitrol thermostat is built to the most exacting standards and is a precision instrument which should never need re-calibration. However through tampering, misuse or other reasons, if the thermostat is found to be more than 10° from normal, re-calibration may be performed by a qualified service technician. Following are the steps for this procedure:

1. Turn the thermostat to OFF to allow the unit to cool down.
2. When the water temperature is room temperature, turn the thermostat dial until the main burner ignites.
3. Slowly turn the thermostat dial counterclockwise until the flame on the burner goes out.
4. Place a thermometer into the water jacket to determine the temperature of the water.
5. Pull off the thermostat dial and lift off the outside cover.
6. Turn the temperature stop to correspond to the actual water temperature. Mark the location of the stop for reference.
7. Turn the stop slowly until the control snaps off. Holding the stop to prevent rotation, carefully loosen the stop adjustment nut (see illustration above).

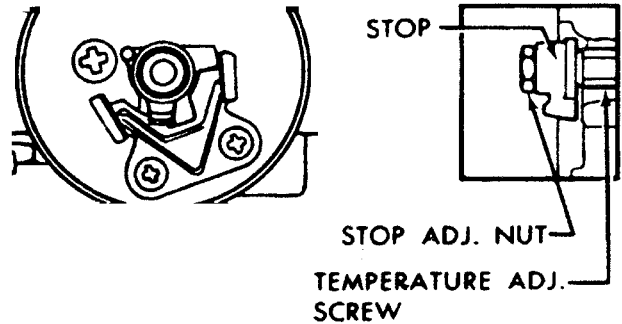

**COPPER WIRE SIZE
REQUIRED**

SINGLE PHASE		THREE PHASE	
6 KW	#10 WIRE	5.25 KW	#12 WIRE
8 KW	#8 WIRE	7.5 KW	#10 WIRE
10 KW	#8 WIRE	9 KW	#8 WIRE
		10.5 KW	#8 WIRE
		12 KW	#8 WIRE
		15 KW	#6 WIRE

ELECTRICAL DATA

MODEL	VOLTS	PHASE	WIRES	WATTS	AMPS	ELEMENTS
RU-150-12	110/220	1	3W + GND	5 KW	22.1	1 - WC-913 -01 220V, 5 KW
RU-150-20	220	3	3W OR 4W + GND	5.25 KW	13.8	1 - WC-907 -01 220V, 1.75 KW LEFT 1 - WC-907 -02 220V, 1.75 KW CENTER 1 - WC-907 -03 220V, 1.75 KW RIGHT
RU-225-12	110/220	1	3W + GND	7 KW	31.8	1 - WC-911 -01 220V, 3.5 KW 1 - WC-911 -02 220V, 3.5 KW
RU-225-20	208/220	3	3W OR 4W + GND	7.5 KW	20	1 - WC-908 -01 220V, 2.5 KW LEFT 1 - WC-908 -02 220V, 2.5 KW CENTER 1 - WC-908 -03 220V, 2.5 KW RIGHT
RU-300-12	110/220	1	3W + GND	6 KW	27.3	2 - WC-910 220V, 3 KW
RU-300-28	208/220	1	3W + GND	8 KW	38	2 - WC-912 220V, 4 KW EA.
RU-300-20	208/220	3	3W OR 4W + GND	7.5 KW	20	3 - WC-908 220V, 2.5 KW EA.
RU-600-12	110/220	1	3W + GND	10 KW	45.5	2 - WC-913 220V, 5 KW EA.
RU-600-28	208/220	1	3W + GND	8 KW	38	2 - WC-912 220V, 4 KW EA.
RU-600-20	220	3	3W OR 4W + GND	10.5 KW	27.6	3 - WC-911 220V, 3.5 KW EA.
RU-1000-12	110/220	1	3W + GND	10 KW	45.5	2 - WC-913 220V, 5 KW EA.
RU-1000-20	208/220	3	3W OR 4W + GND	10.5 KW	27.5	3 - WC-911 220V, 3.5 KW EA.

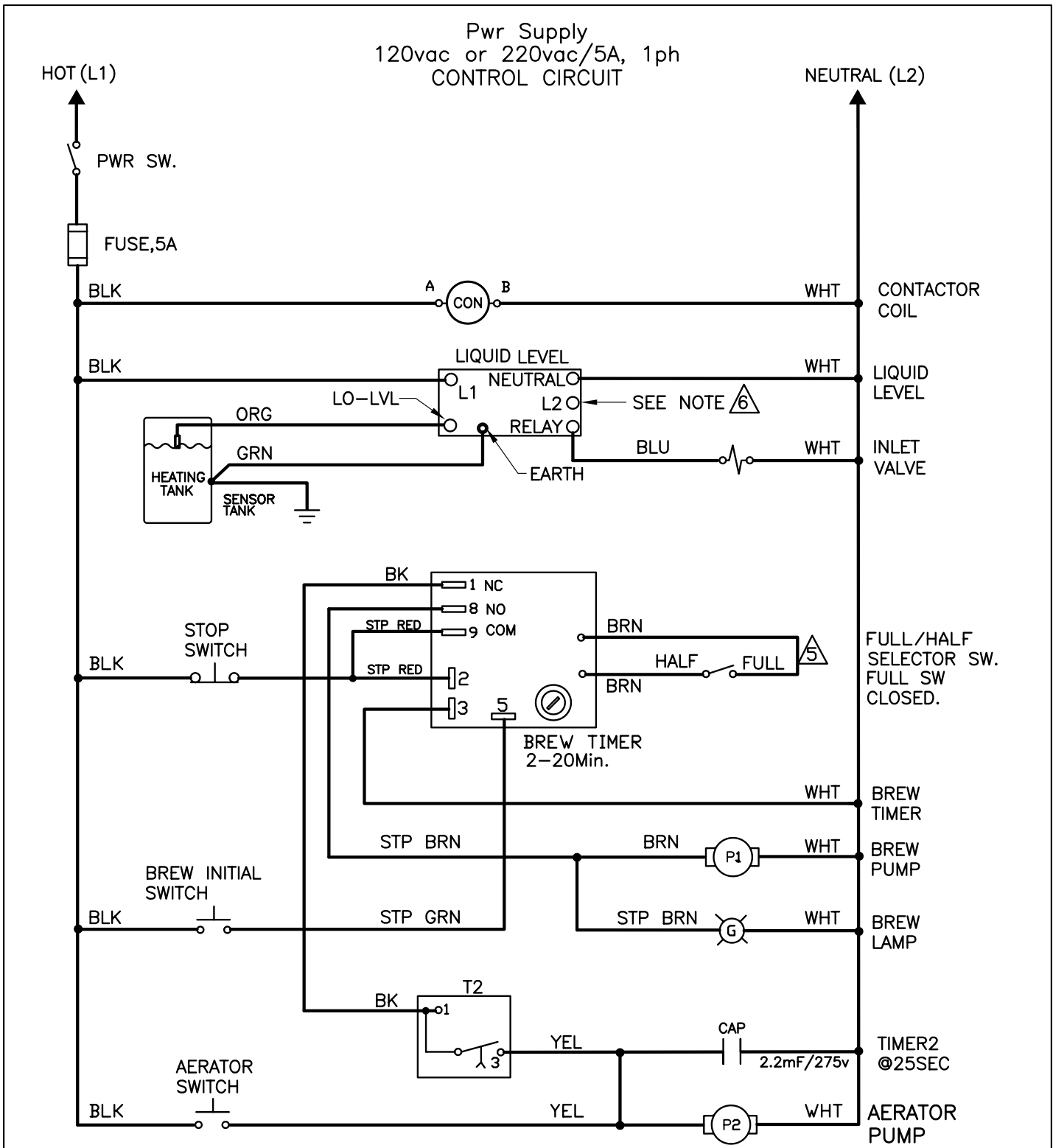

- ⚠ WHEN USING 220VAC CONFIGURATION CONNECT WHITE WIRE FROM NEUTRAL TO L2.
- ⚠ FULL & 1/3 BATCH FOR RU1000. FULL AND HALF BATCH FOR RU150/225/300/600.
- 4 ALL COMPONENTS IN CONTROL CIRCUIT WILL BE 120VAC OR 220VAC DEPEND ON POWER SUPPLY AND CIRCUIT CONFIGURATION.
- 3 USE THIS DIAGRAM FOR OTHER MODELS WITH ADDED PREFIX AND/OR WITH SECOND DASH NUMBER ON THEIR PART NUMBERS PROVIDED THEY HAVE THE SAME ELECTRICAL SPECS AND/OR RATINGS.
- 2 DO NOT CHANGE NOR SUBSTITUTE WIRE COLORS. ALL WIRES SHALL BE 18AWG.
- 1 ALL WIRES SHALL BE UL APPROVED APPLIANCE
- NOTES: UNLESS OTHERWISE SPECIFIED

VOLTAGE:	120/240
WATTAGE:	600
AMPERAGE:	5A
HERTZ:	50/60
WIRES:	2W + G
PHASE:	1 PH

TITLE: LADDER DIAGRAM CONTROL CIRCUIT, STD.	
PART NUMBER: LD-RUCNTRL-100	REVISION: B

Configuration #12
Heater Circuit
3PHASE 3W+G
With 120VAC POWER CORD CNTRL CIRCUIT

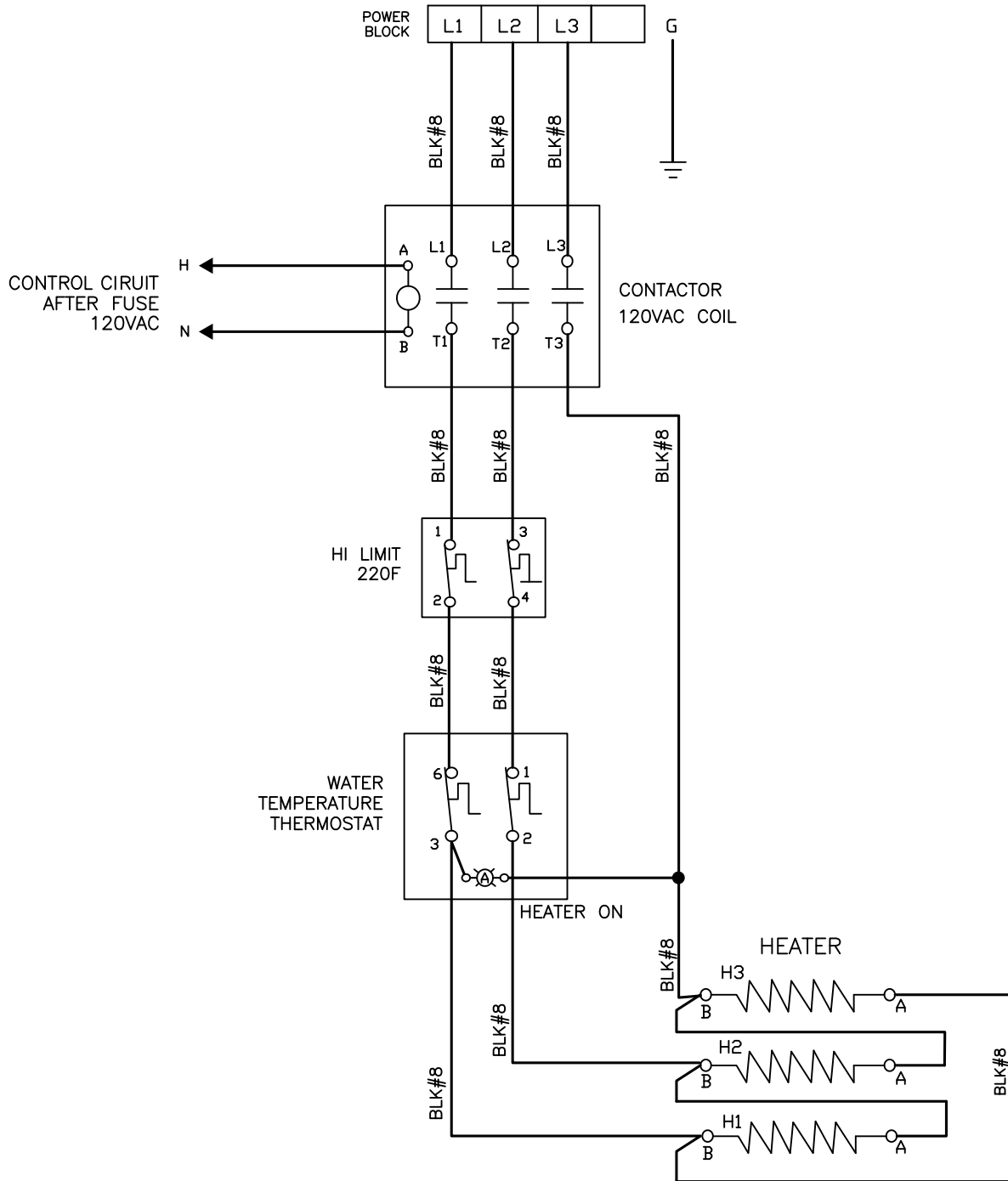

NOTES:

1. CONTACTOR COIL CONNECT TO CONTROL CIRCUIT AFTER FUSE
2. 120VAC POWER CORD CONNECT TO CONTROL CIRCUIT (LD-RUCNTRL-100 AT H & N)

VOLTAGE:	SEE BOM
WATTAGE:	SEE BOM
AMPERAGE:	SEE BOM
HERTZ:	50/60
WIRES:	3W + G
PHASE:	3 PH

TITLE: LADDER DIAGRAM HEATER CIRCUIT	
PART NUMBER: LD-RUHTR-112	REVISION: NC

Configuration #3
Heater Circuit
Single Phase 3W+G

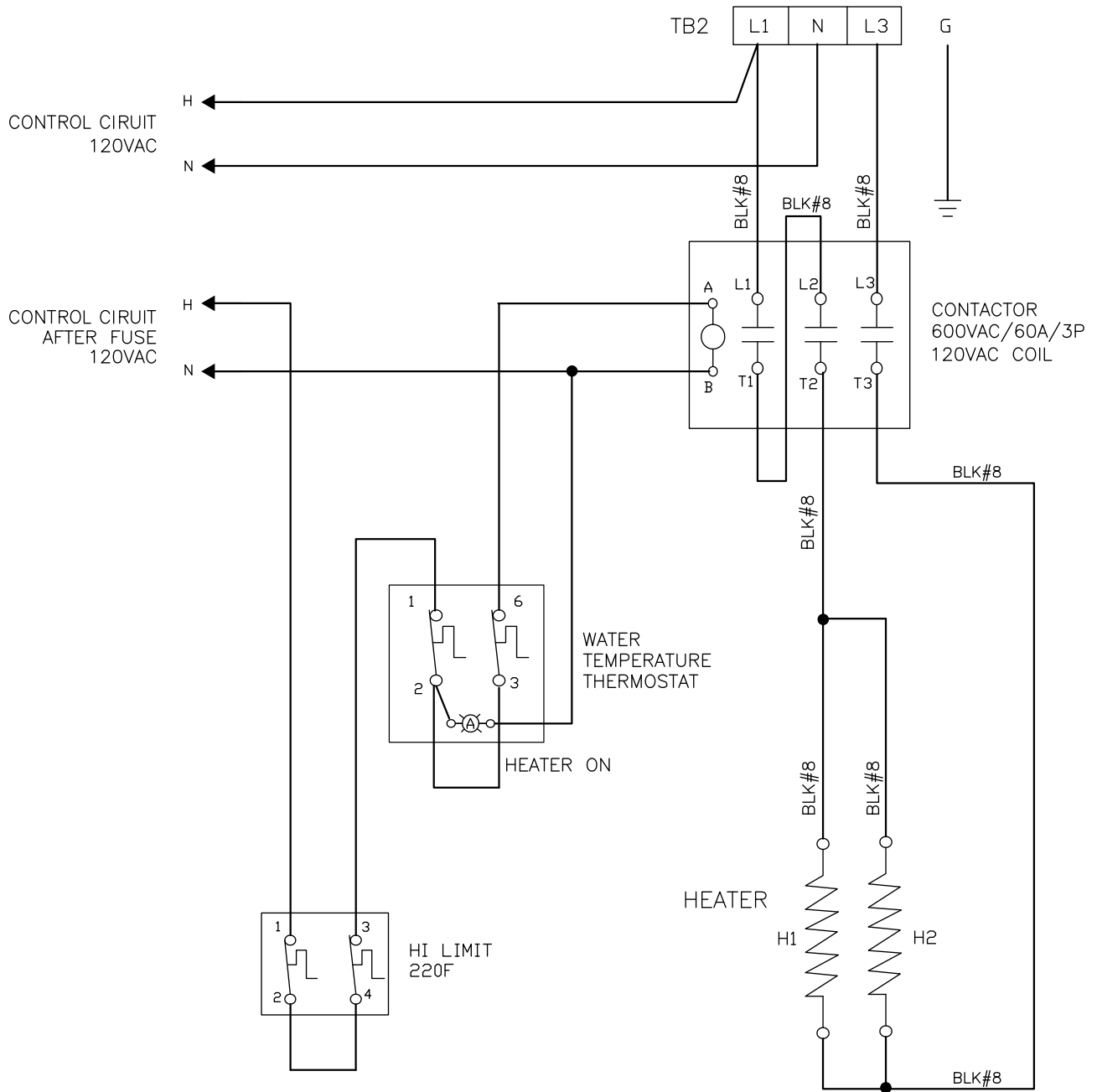

NOTE:
1. THIS CONFIGURATION APPLIES TO
HEATER CIRCUIT EXCEEDING 40A

VOLTAGE:	SEE BOM
WATTAGE:	SEE BOM
AMPERAGE:	SEE BOM
HERTZ:	50/60
WIRES:	3W + G
PHASE:	1 PH

TITLE:	LADDER DIAGRAM HEATER CIRCUIT	
PART NUMBER:	LD-RUHTR-103	REVISION:
		NC

WATER LEVEL CONTROL OPERATION

For the contact points referenced in this section, see the schematic diagram below.

Components involved:

1. **Probe Assembly**
2. **Liquid Level Control Board**
3. **Water Inlet Valve Assembly**

PROBLEM: Water is not flowing into the urn jacket.

PROCEDURE:

Turn off the unit and test the probe assembly and check for grounded wiring. Pull the orange wire from the terminal of the liquid level control board at point **A**, with the quick disconnect terminal attached to the orange wire and with the other lead of the meter, touch the metal surface of the urn. Any reading in the meter dial will indicate the presence of a short to ground in either the terminals, wire or probe assembly. Find the short and repair it. If there is no reading at all on your ohmmeter, the probe is okay. Return the orange wire to terminal 4 of the liquid level control board where it was removed.

Turn the unit on and clamp the leads of your voltmeter at the terminals of the valve coil as shown at **B** of the illustration below. Under normal conditions, the voltmeter should read 110 to 120 Volts while the urn is filling up and power to the coil should stop once the water level reaches the probe tip. If the voltmeter does not show voltage, the liquid level control board is not working properly. It is not sending power to the solenoid valve and the valve does not open. Replace the board.

If both the probe and the liquid level control board are functioning normally, check the water inlet valve. Turn on the unit and disconnect the white and the blue wires from the coil on the valve (points **B**). Use a lamp cord with alligator clips; hookup the terminals to the cord. Plug the cord into a 120 Volt outlet. The valve should open when plugged in and close when unplugged. Repeat this three or four times. If you don't hear the sound of the solenoid, then the coil is bad. If you hear water flowing through the valve when unplugged, the diaphragm is either torn or needs cleaning. Replace the water inlet valve.

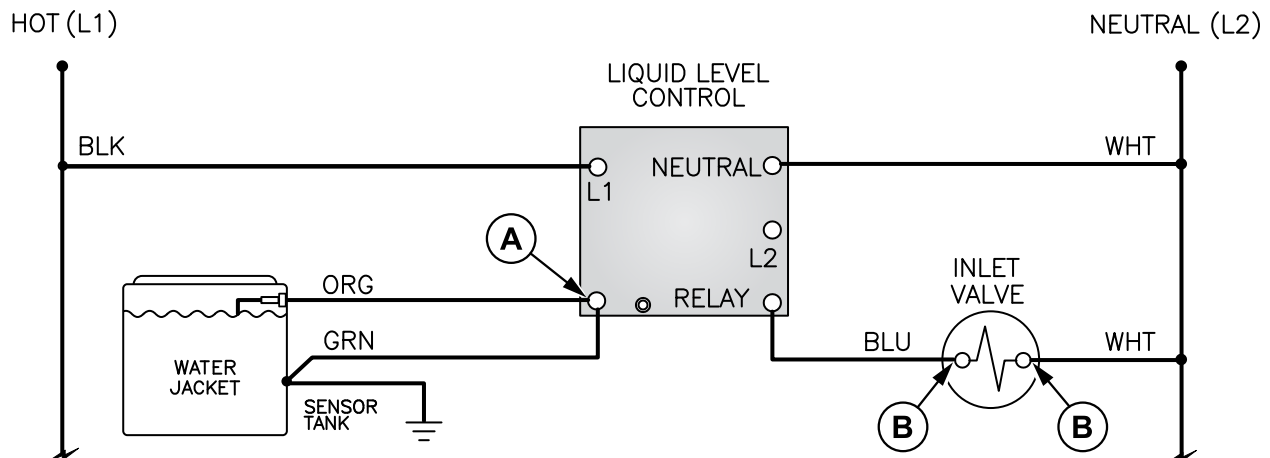

BREWING OPERATION

For the contact points referenced in this section, see the schematic diagram below.

Components involved:

1. Fuse
2. Brew Switch
3. Timer
4. Stop Switch
5. Water Pump

PROBLEM: The brew switch light does not turn on when pressed.

Test: Check the power supply and the fuse in the control box. It may be burned out.

Problem: The brew switch does not stay on, or light stays on only while the switch is pressed, but turns off when released and water comes out of spray head only while the switch is kept pressed.

Test the Brew Switch: Take a voltage reading at point **A** while the brew switch is pushed in. If you read 110 volts, it means that the switch is good.

Test the Timer: The timer resets itself to the N. O. position after every brewing cycle but if it fails to stop itself, it will remain closed and cause the problem in question.

To check the timer, **power to the control circuit must be turned off.** Disconnect the STP RED (point B) and STP BRN (point C) wires and take a continuity test between the two terminals 8 and 9 on the timer. If there is continuity, the timer is faulty and must be replaced.

Test the Water Pump: To test the water pump, press the brew switch and take a voltage reading between points E and F. If there is voltage and the pump does not run, replace the pump.

Test the Stop Switch: The last of the components involved in this operation is the stop button. The only function of the switch is to interrupt the current that energizes the timer after the brew switch has been depressed. A voltage reading at N.O. of the timer (point D) will indicate an open or closed condition.

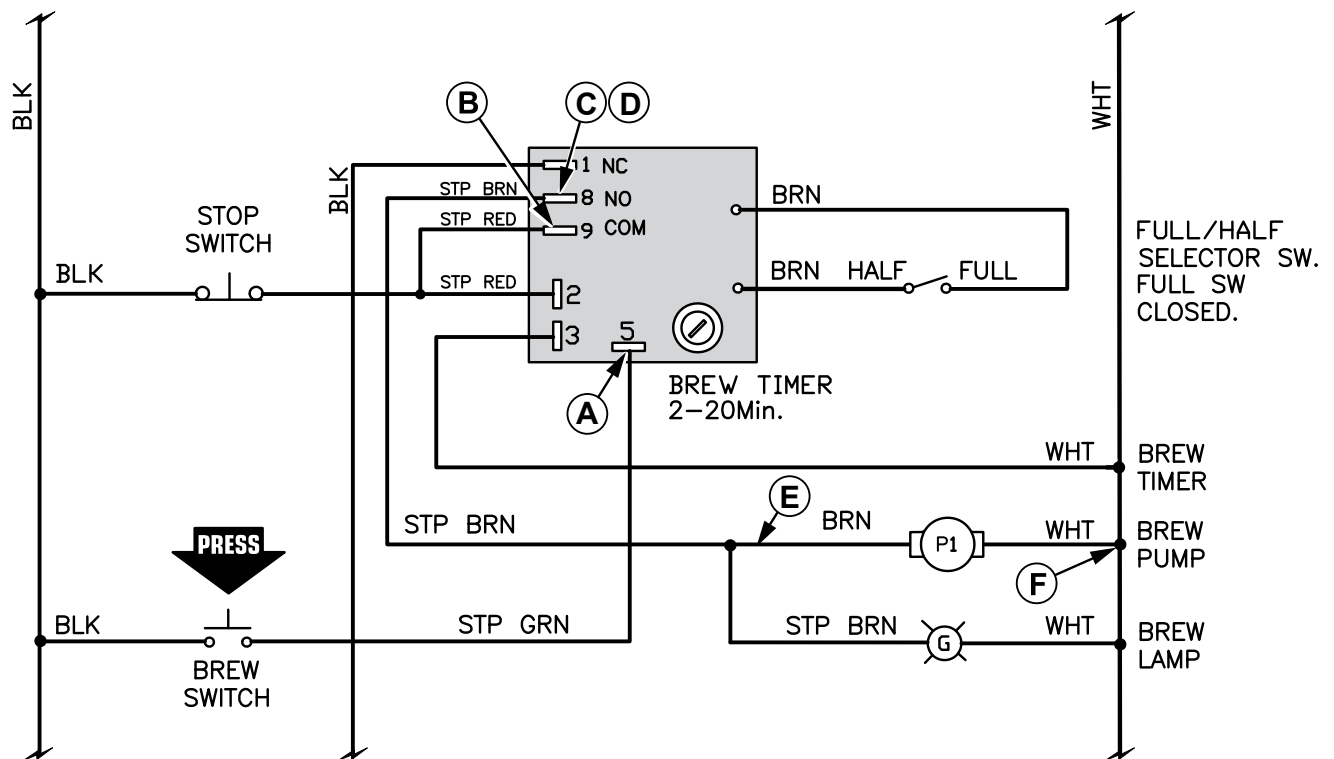

AERATION SYSTEM

For the contact points referenced in this section, see the schematic diagram below.

Components involved:

1. Aeration Tubes
2. Air Pump
3. Aeration Timer
4. Manual Aeration Switch

AUTOMATIC AERATION

PROBLEM: Only one of the liners is aerated.

TEST: Inside the control box, there are two silicone tubes connecting the aeration pump to the 1/4" copper tubes coming from inside the urn. Carefully, pull the silicone tubes from the copper tubes, press the manual aeration button and feel for air flow from the silicone tubes. Replace the pump if air does not blow through the tubes.

Air Pump Tubes.

NOTE: When replacing the silicone tubing on the copper tubes, make sure you do not cover the small holes on the copper tubes.

These are air release holes that pump into the liner so coffee can refill the gauge glass.

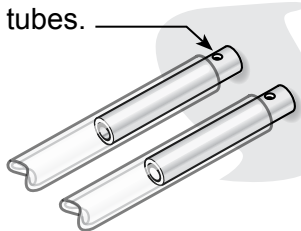

PROBLEM: Aeration system fails to operate automatically.

TEST: Determine that the aeration pump is operating by pressing the manual aeration button on the front panel to see that air comes from the tubes.

AGITATION TIMER

Check the agitation timer. Remove the black wire from point A, terminal 1 on the timer. Disconnect the black wire from the aerator switch (point B). Plug this wire into the terminal 1 of the timer (dashed line). The air pump should immediately start pumping air into the liner. If this test fails, replace the agitation timer WC-405R. If the pump runs normally, then reconnect the wires at their normal connection points and proceed to test the aeration switch as instructed below.

MANUAL AERATION

PROBLEM: Manual aeration is not present on either of the liners, yet automatic aeration operates normally.

TEST: Check the continuity of the manual aeration switch. Power to the control circuit must be turned off to check for continuity. Check at the yellow wire at point C of the agitation timer and B (black wire) of the manual aeration switch. Press the switch to look for continuity. Check for clean, tight connections at all terminals.

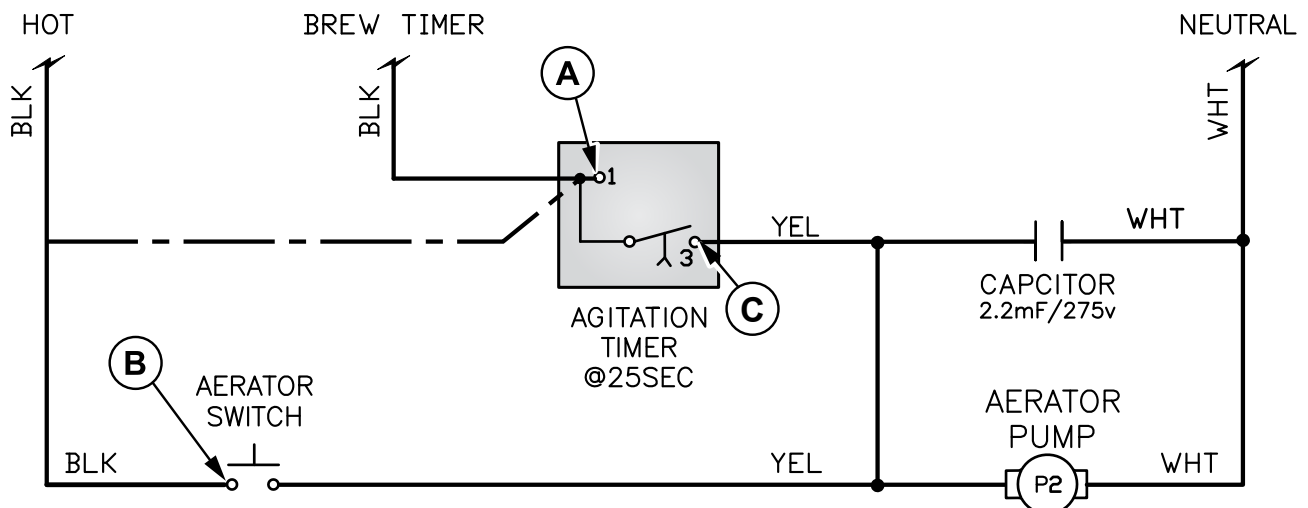

Product Warranty Information

Wilbur Curtis Co., Inc. certifies that its products are free from defects in material and workmanship under normal use. The following limited warranties and conditions apply:

3 years, parts and labor, from original date of purchase on digital control boards.

2 years, parts, from original date of purchase on all other electrical components, fittings and tubing.

1 year, labor, from original date of purchase on all electrical components, fittings and tubing.

Additionally, Wilbur Curtis Co., Inc. warrants its grinding burrs for forty (40) months from date of purchase or 40,000 pounds of coffee, whichever comes first. Stainless steel components are warranted for two (2) years from date of purchase against leaking or pitting and replacement parts are warranted for ninety (90) days from date of purchase or for the remainder of the limited warranty period of the equipment in which the component is installed. All in-warranty service calls must have prior authorization. For authorization, call the Technical Support Department at 1-800-995-0417. Effective date of this policy is April 1, 2003. Additional conditions may apply. Go to www.wilburcurtis.com to view the full product warranty information.

CONDITIONS & EXCEPTIONS

The warranty covers original equipment at time of purchase only. Wilbur Curtis Co., Inc., assumes no responsibility for substitute replacement parts installed on Curtis equipment that have not been purchased from Wilbur Curtis Co., Inc. Wilbur Curtis Co., Inc. will not accept any responsibility if the following conditions are not met. The warranty does not cover and is void under the following circumstances:

- 1) Improper operation of equipment: The equipment must be used for its designed and intended purpose and function.
- 2) Improper installation of equipment: This equipment must be installed by a professional technician and must comply with all local electrical, mechanical and plumbing codes.
- 3) Improper voltage: Equipment must be installed at the voltage stated on the serial plate supplied with this equipment.
- 4) Improper water supply: This includes, but is not limited to, excessive or low water pressure and inadequate or fluctuating water flow rate.
- 5) Adjustments and cleaning: The resetting of safety thermostats and circuit breakers, programming and temperature adjustments are the responsibility of the equipment owner. The owner is responsible for proper cleaning and regular maintenance of this equipment.
- 6) Damaged in transit: Equipment damaged in transit is the responsibility of the freight company and a claim should be made with the carrier.
- 7) Abuse or neglect (including failure to periodically clean or remove lime accumulations): The manufacturer is not responsible for variation in equipment operation due to excessive lime or local water conditions. The equipment must be maintained according to the manufacturer's recommendations.
- 8) Replacement of items subject to normal use and wear: This shall include, but is not limited to, light bulbs, shear disks, "O" rings, gaskets, silicone tube, canister assemblies, whipper chambers and plates, mixing bowls, agitation assemblies and whipper propellers.
- 9) Repairs and/or replacements are subject to our decision that the workmanship or parts were faulty and the defects showed up under normal use. All labor shall be performed during regular working hours. Overtime charges are the responsibility of the owner. Charges incurred by delays, waiting time, or operating restrictions that hinder the service technician's ability to perform service is the responsibility of the owner of the equipment. This includes institutional and correctional facilities.

Wilbur Curtis Co., Inc. will allow up to 100 miles, round trip, per in-warranty service call. RETURN MERCHANDISE AUTHORIZATION: All claims under this warranty must be submitted to the Wilbur Curtis Technical Support Department prior to performing any repair work or return of this equipment to the factory. All returned equipment must be repackaged properly in the original carton. No units will be accepted if they are damaged in transit due to improper packaging. NO UNITS OR PARTS WILL BE ACCEPTED WITHOUT A RETURN MERCHANDISE AUTHORIZATION (RMA). THE RMA NUMBER MUST BE MARKED ON THE CARTON OR SHIPPING LABEL. All in-warranty service calls must be performed by an authorized service agent. Call the Wilbur Curtis Technical Support Department to find an agent near you.

