



# ELECTRIC PROFESSIONAL SLICERS

S.R.L

VIA GIOVANNI XXIII, 11 — 22072 CERMENATE (COMO) ITALY — TEL.: +39 031 722 819 — FAX: +39 031 722 825

www.rgv.it — E-mail: info@rgv.it

E-mail USA e CANADA: ferzuc@yahoo.com — E-mail ARGENTINA: expoezeq@arnet.com.ar



SERIE **DOLLY**  
automatic

Mod. **AU 300/S**

Mod. **AU 350/S**

## TECHNICAL CHARACTERISTICS

Cast aluminium structure **anodized base** ● Tempered professional blade

Blade cover, tray and bulkhead: in anodized aluminium ● Fixed blade protection ring

Shaft holding the blade mounted on a double ball-bearing ● Protection on the tray in transparent material

Professional ventilated motor 230V - 50Hz ● Slicing thickness up to 14 ÷ 16 mm

Different voltage by request ●

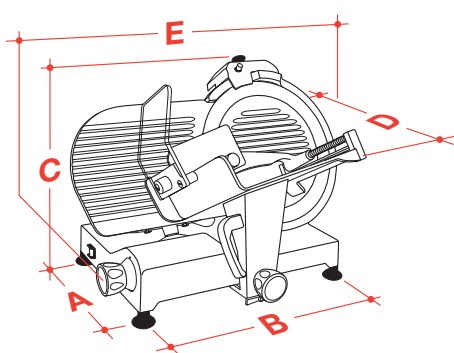

MOD.	AU 300/S	AU 350/S
A mm	315	385
B mm	455	540
C mm	420	480
D mm	480	515
E mm	570	680
Blade diameter (Ø)	mm 300	mm 350
Motor power	Watt 160	Watt 380
Capacity of cutting about	mm 245 x 220	mm 245 x 220
Cuts in a minute	n° 36	n° 36
Motor power automatic advancement (IP 54 protection)	Watt 350	Watt 350
Gross weight	kg 49	kg 63
Packing dimensions	cm 63 x 52 x 62	cm 75 x 68 x 80
	m³ 0,2	m³ 0,4

