

MP 550 Ultra



EasyPlug



D

Pan capacity

up to 200 litres

▶ Specially designed for intensive use in commercial/institutional catering

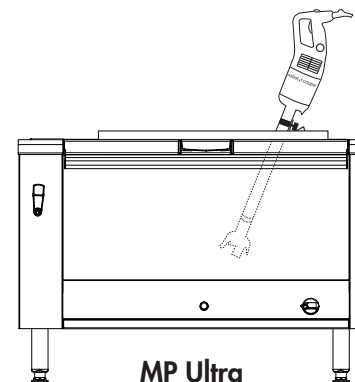

A SALES DESCRIPTION

Ideal for blending soups and puréeing fruit and vegetables. Special institutional catering model intended for intensive use

B TECHNICAL DESCRIPTION

MP 550 Ultra immersion blender. Single phase. Power: 750 W. Speed: 9,000 rpm. 100% stainless-steel blades, bell and tube (total length: 550 mm). "EasyPlug" system featuring detachable power cord

C TECHNICAL DATA

Output power	750 W	
Electrical datas	Single phase - Plug supplied	
Speed	9,000 rpm	
Rate of recyclability	95%	
Net weight	5.2 kg	
	Supply	Amperage
	220-240/50-60/1	3.5 Amp
	240V/50/1 UK plug	3.5 Amp
	120V/60/1	6.5 Amp
	220V/60/1 SAU*	3.5 Amp
		Reference
		34820LH
		34821LH
		34825LH
		34828LH

*For commercial use only

STANDARDS

EN 12100-1 & 2-2004, EN 60204-1-2006, EN 12853, EN 60529-2000 : IP55 & IP34



E CHARACTERISTICS AND BENEFITS

MOTOR UNIT

- Power 750 W
- Stainless-steel motor unit with air vents in the top section only to ensure watertightness
- Lug on motor housing serves as a rest and pivot on the pan rim for greater user comfort
- Speed 9,000 rpm
- Self-regulating speed system
- New patented "EasyPlug" system making it easier to replace the power cord during after-sales servicing
- Cord winding system for tidy storage and optimum lifespan

TUBE AND BELL

- 100% stainless-steel blades, bell and tube (total length: 550 mm).
- Foot with detachable bell and blades (patented system exclusive to Robot-Coupe)
- Watertight bell design for optimum lifespan

STANDARD ATTACHMENTS

- Wall-mounted immersion blender holder
- Tool for fixing and detaching the blades

MP 550 Ultra

F ATTACHMENTS

Optional attachments:

- 3 adjustable stainless-steel pan supports:
 - Ref. 27363 – for pans with a diameter of 330 650 mm
 - Ref. 27364 – for pans with a diameter of 500 1000 mm
 - Ref. 27365 – for pans with a diameter of 850 1300 mm
- 1 universal pan support:
 - Ref. 27358 – screws onto pan rim



Standard attachments:

- EasyGrip removable handle:
 - Ref 27359



G DRAWINGS & DIMENSIONS

Power cord and plug supplied

