

Client _____ Quantity _____
 Project _____ Position _____



Function oven

Function oven Electromechanical convection Electric oven 6 trays GN 1/1 hinged door

Model: GEU611

Cod: NP01061021001

Technical data

Number of pans:	6
Pans size (mm):	GN 1/1
Tray centre distance (mm):	75
Number of fans:	2
Fan speed:	1
Dimensions (mm):	833 x 780 x 711
Net weight (Kg):	75
Volume (m3):	0,465
Chamber size (mm):	618 x 435 x 508
Electric power (kW):	7,7
Voltage (V):	380-415
Power supply (A):	17
Phases:	3N
Cable section (mmq):	5G2,5
Frequency (Hz):	50-60
Cold water connection:	3/4"
Cold water pressure (bar):	Max 5 bar

Features

Oven type:	Convection
Control:	Electro-mechanic ovens
Functions:	Convection cooking, cooking with humidity
Steam:	Direct
Steam management:	Pressione
Temperature range:	50°C - 300°C
Door:	Hinged door
Cooking chamber bottom:	AISI 430 mirror finish
Range timer:	1' - 120'
Flue:	Sempre aperto

Cosmo:

Technical draw

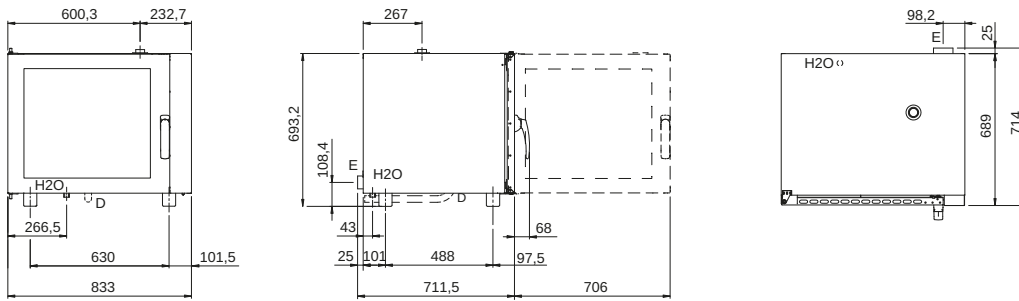

E: Electric connection

D: Drain for water