

Client _____ Quantity _____
 Project _____ Position _____



Pratika oven

Pratika oven Electric combi touch screen 10 trays EN 600x400 - GN 1/1

Model: FDE101TV

Cod: NP01102023005

Technical data

Number of pans:	10
Pans size (mm):	EN 600x400 - GN 1/1
Tray centre distance (mm):	74
Number of fans:	2
Fan speed:	2
Dimensions (mm):	905 x 845 x 1110
Net weight (Kg):	135
Volume (m3):	0,850
Chamber size (mm):	645 x 449 x 800
Electric power (kW):	15,8
Voltage (V):	380-415
Power supply (A):	26
Phases:	3N
Cable section (mmq):	5G4
Frequency (Hz):	50-60
Cold water connection:	3/4"
Cold water pressure (bar):	Max 5 bar

Features

Oven type:	Combi
Control:	Touch screen
Touch screen:	5"
Cooling:	Funzione raffreddamento camera rapido
Probe:	Standard - one single point core probe
Washing:	Di serie - Circuito aperto
Detergent:	Liquido
Steam:	Direct
Steam management:	Automatic
Temperature range:	30°C - 280°C
Door:	Hinged door
Flue:	Automatic
Recipes:	Standard

Cosmo:

Technical draw

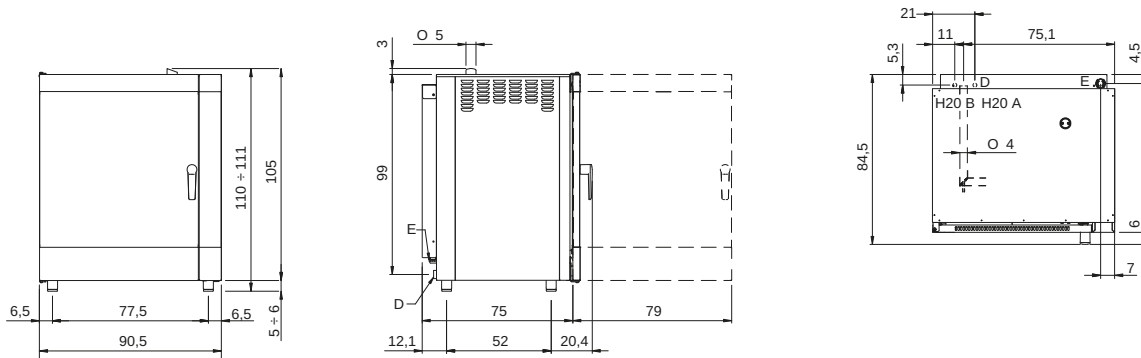

E: Electric connection

D: Drain for water

H2O A: Water inlet

H2O B: Softened water inlet