

Client _____ Quantity _____
 Project _____ Position _____



Pratika oven

Pratika oven Gas electromechanical Combi-Oven 10 trays EN 600x400 - GN 1/1

Model: FDG101V

Cod: NP01102033002

Technical data

Number of pans:	10
Pans size (mm):	EN 600x400 - GN 1/1
Tray centre distance (mm):	74
Number of fans:	2
Fan speed:	2
Dimensions (mm):	905 x 845 x 1130
Net weight (Kg):	140
Volume (m3):	0,865
Chamber size (mm):	645 x 449 x 800
Electric power (kW):	0,8
Voltage (V):	220-240
Power supply (A):	3,5
Phases:	1N
Cable section (mmq):	3G1,5
Frequency (Hz):	50
Gas power (kW):	19
Total gas power (Kcal/h):	16337

Features

Oven type:	Combi
Control:	Electro-mechanic ovens
Steam:	Direct
Steam management:	Time management
Temperature range:	30°C - 280°C
Door:	Hinged door
Fan:	Realizzata in acciaio inox AISI 304 - autoreverse
Cooking chamber bottom:	Stainless steel cooking chamber
Range timer:	1' - 120'
Flue:	Manual input

Cosmo:

Technical draw

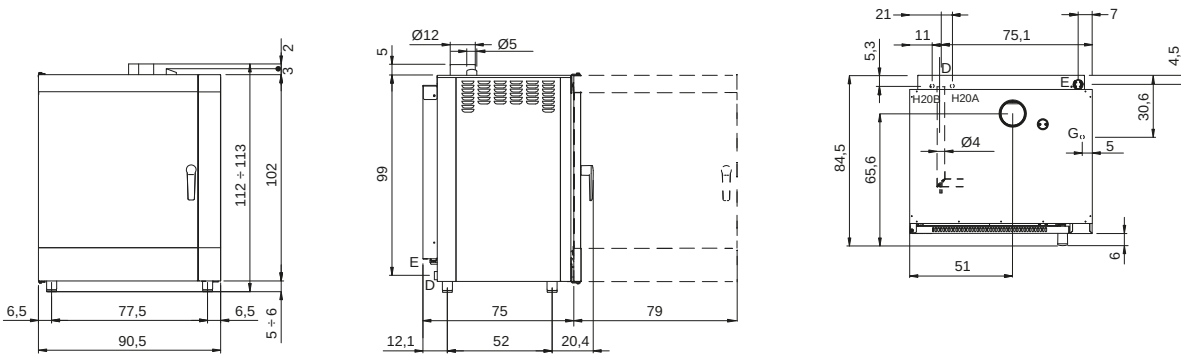

G: Gas connection

E: Electric connection

D: Drain for water

H2O Water inlet

H2OB Softened water inlet