

SM 4500



FROZEN ICE



Modular ice maker - Scale system
Daily production up to 2450 kg

• Position n°



• Application fields

Hotel	●●●●●●●●●●	Fish market	●●●●●●●●●●
Restaurant	●●●●●●●●●●	Supermarket	●●●●●●●●●●
Fast food	●●●●●●●●●●	SPA	●●●●●●●●●●
Bar	●●●●●●●●●●	Medical	●●●●●●●●●●
Disco	●●●●●●●●●●	Industry	●●●●●●●●●●

• Features & Plus

- Subcooled flakes (from -5°C to -10°C)
- Low consumption (1 liter water / 1 kg ice)
- Electromechanical functioning
- External structure AISI 304 Scotch Brite
- Stainless steel frame
- Evaporator anticorrosion alloy made, with rotating knife
- Air Cooling and Water Cooling systems
- Standard and special voltages
- 1 m³ = 430 kg of ice
- ABS plastic components, FDA approved
- Easy cleaning thanks to rounded surfaces
- Cleanable antiscaling filter
- Removable and cleanable air filter
- Conformity to RoHS directive
- Automatic water charge
- Model in Tropical Class + 43 °C

• Prod. 24h

Air temp.	Water temp.	Prod. 24h kg
10° C	10° C	2450
21° C	15° C	2300
32° C	21° C	2034

2 Years Warranty

subject to limitations

• Certifications available for this model



www.ntfice.it
info@ntfice.it



ntfice.it



SM 4500



FROZEN ICE



Modular ice maker - Scale system
Daily production up to 2450 kg

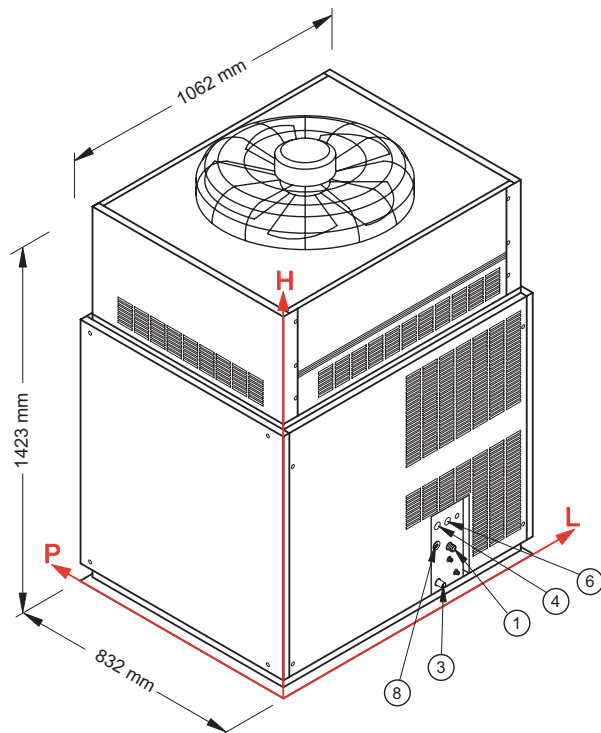

• Connections

All measures are referred to the rear bottom-left corner (L-H-Ø)

- ① Water inlet:
684 mm - 192 mm - 3/4"
- ③ Water outlet:
659 mm - 65 mm - 24 mm
- ④ Electrical connection:
651 mm - 271 mm
- ⑥ Remote connection:
693 mm - 271 mm
- ⑧ Connection to saline solution dosing pump:
640 mm - 232 mm

• Working conditions

- Location: Indoor

	Min	Max
Ambient temperature	+10° C	+43° C
Water temperature	+3° C	+32° C
Voltage	-10%	+10%
Water inlet pressure	1bar (14 psi)	6bar (84 psi)

• Technical information

Production in 24h	2300 kg
Cooling system	A
Refrigerant	R404A - R452A
Standard voltage	400-415 V ~ 3N 50 Hz
Electrical consumption	7000 W
Fuse	32 A
Water consumption	1 l/kg
Sizes (L-P-H mm)	1062 - 832 - 1423
Sizes with pack (L-P-H mm)	1150 - 960 - 1700
Net weight	520 kg
Gross weight	570 kg
Finish	AISI 304 stainless steel, scotch brite

All the technical information must be considered at the following conditions:



Ambient temperature
+21° C



Water temperature
+15° C



Electrical consumption
at +21° C
(standard voltage)

Models and specifications are subject to change without notice
Rev. 02 - Issued September 2019



www.ntfice.it
info@ntfice.it



ntfice.it

